



7KC SERIES

SERVICE MANUAL



CREDITS/COPYRIGHT

©2001–2002 Best Lock Corporation dba Best Access Systems. All rights reserved.
Printed in the United States of America.

Information in this document is subject to change without notice and does not represent a commitment on the part of Best Access Systems. The software described in this document are furnished under a license agreement or nondisclosure agreement.

This publication is intended to be an accurate description and set of instructions pertaining to its subject matter. However, as with any publication of this complexity, errors or omissions are possible. Please call your BEST distributor or Best Access Systems at (317) 849-2250 if you see any errors or have any questions. No part of this manual and/or databases may be reproduced or transmitted in any form or by any means, electronic or mechanical, including photocopying, recording, or information storage and retrieval systems, for any purpose, without the express written permission of Best Access Systems.

This document is distributed as is, without warranty of any kind, either express or implied, respecting the contents of this book, including but not limited to implied warranties for the publication's quality, performance, merchantability, or fitness for any particular purpose. Neither Best Access Systems, nor its dealers or distributors shall be liable to the user or any other person or entity with respect to any liability, loss, or damage caused or alleged to be caused directly or indirectly by this publication.

The Best Access Systems logo is a registered trademark of Best Lock Corporation.

Written and designed by Best Access Systems and Avalon Group, Inc., Indianapolis, Indiana.

T80621 Rev A 1832441 ER7991-6 April 2002

CONTENTS

FIGURES v

GETTING STARTED 1-1

- Introduction 1-1
- Certifications and standards 1-1
- Documentation package 1-2
- Technical support 1-3
 - Support services 1-3
 - Telephone technical support 1-3

FUNCTIONS AND PARTS LISTS 2-1

- Function descriptions 2-2
 - Single-keyed functions 2-2
 - Non-keyed functions 2-3
 - Functions by ANSI designation 2-3
- AB function chassis and trim—entrance lock (ANSI F109) 2-4
- Trim parts 2-5
 - Strikes and strike boxes 2-5
 - Roses 2-6
 - Buttons 2-6
 - Standard levers and throw member 2-7
 - Non-IC lever and core 2-8
 - Latches 2-9
 - Installation tools 2-10

SERVICE AND MAINTENANCE 3-1

Replacing parts 3-2

 Replacing the lever 3-2

 Replacing the inside rose 3-5

 Replacing the outside rose 3-6

 Replacing the button assembly 3-8

Lubricating the cores 3-10

Aligning the chassis and trim 3-11

Troubleshooting 3-12

INSTALLATION INSTRUCTIONS A-1

INDEX B-1

FIGURES

FUNCTIONS AND PARTS LISTS

- Understanding function drawings 2-2
- AB function exploded diagram 2-4
- Strikes and strike boxes 2-5
- Roses 2-6
- Buttons 2-6
- Standard levers 2-7
- Throw member 2-8
- Non-IC lever and core 2-8
- Latches 2-9
- Installation tools 2-10
- Boring jig kit 2-11

SERVICE AND MAINTENANCE

- Removing the keyed lever 3-2
- Removing the plain lever or button lever 3-3
- Reinstalling the lever (keyed lever shown) 3-4
- Removing the inside rose with the screwdriver 3-5
- Reinstalling the inside rose and rose liner 3-6
- Removing the outside rose 3-7
- Reinstalling the outside rose 3-7
- Engaging the retractor in the latch 3-8
- Removing the button assembly 3-9
- Inserting the button assembly into the sleeve 3-9
- Engaging the retractor in the latch 3-11
- Adjusting the outside rose and liner assembly 3-12

1

GETTING STARTED

INTRODUCTION

The *7KC Series Service Manual* contains essential information to help you maintain your 7KC Series Lock.

CERTIFICATIONS AND STANDARDS

- The product complies with ANSI A156.2, Series 4000 Grade 2 standards; California Administrative Code Title 19 and Title 24; Illinois Accessibility Standard.
- The locks are listed by Underwriter's Laboratories for use on 3 Hr., A label single swinging doors (4' x 8').
- The 6KS2 and 6KS3 strike fits the standard door frame cutout as specified in ANSI A115.2.

DOCUMENTATION PACKAGE

The following documentation is available to help you with the installation, start-up, and maintenance of your 7KC Series Lock.

The installation and assembly instructions also can be ordered separately:

Document Title	Doc. No.
<i>BEST Installation Instructions for 72KC-75KC Cylindrical Locks</i>	T80622
<i>BEST Installation Instructions for 7KC Non-IC Cores and Throw Members</i>	T80628
<i>Installation Instructions for 7KC 1DT and 9K 1DT/2DT Dummy Trim Assemblies.</i>	T56076

The templates required for lock installations also can be ordered separately:

Document Title	Doc. No.
<i>K08 Template for Door and Frame Preparation for 63K, 73KC, 83K, 93K Cylindrical Locks with Small (STK) Strike</i>	T56052
<i>K09 Template for Door and Frame Preparation for 63K, 73KC, 83K, 93K Cylindrical Locks with Large (S3) Strike</i>	T56053
<i>K10 Template for Door and Frame Preparation for 64K, 74KC, 84K, 94K Cylindrical Locks with Small (STK) Strike</i>	T56054
<i>K11 Template for Door and Frame Preparation for 64K, 74KC, 84K, 94K Cylindrical Locks with Large (S3) Strike</i>	T56055
<i>K12 Template for Door Frame Preparation for 65K, 75KC, 85K, 95K Cylindrical Locks with Small (STK) Strike</i>	T56056
<i>K13 Template for Door Frame Preparation for 65K, 75KC, 85K, 95K Cylindrical Locks with Large (S3) Strike</i>	T56057
<i>K18 Template for 7KC, 8K, 9K Dummy Trim</i>	T56059
<i>K21 Template for Strike Specification for 6K, 7KC, 8K, 9K Cylindrical Locks</i>	T56060
<i>Template for 3 3/4" and 5" Backset for 6K, 7KC, 8K, 9K Cylindrical Locks with RQE</i>	T56077
<i>Template for 2 3/4" Backset for 6K, 7KC, 8K, 9K Cylindrical Locks with RQE</i>	T56091
<i>Template for 2 3/8" Backset for 6K and 7KC Cylindrical Locks</i>	T56092

TECHNICAL SUPPORT

Support services When you have a problem with the 7KC Series Lock, your first resource for help is the *7KC Series Service Manual*. If you cannot find a satisfactory answer, contact your local BEST Representative.

Telephone technical support A factory-trained Certified Product Specialist (CPS) is available in your area whenever you need help. Before you call, however, please make sure you are where the 7KC Series Lock is, and that you are prepared to give the following information:

- what happened and what you were doing when the problem arose
- what you have done so far to solve the problem.

Best Access Systems Representatives provide telephone technical support for all 7KC Series products. You may locate the representative nearest you by calling (317) 849-2250 Monday through Friday, between 7:00 a.m. and 4:00 p.m. eastern standard time; or visit the web site, www.BestAccess.com.

2

FUNCTIONS AND PARTS LISTS

The following pages contain function descriptions for all 7KC Series Locks. This chapter also includes an exploded diagram of a lock as well as diagrams of trim and other miscellaneous parts.

FUNCTION DESCRIPTIONS

This section includes function descriptions grouped by the following function types:

- single-keyed (page 2-2)
- non-keyed (page 2-3)
- ANSI designation (page 2-3).

Note: If the function is ANSI defined, the ANSI designation appears by the function name.

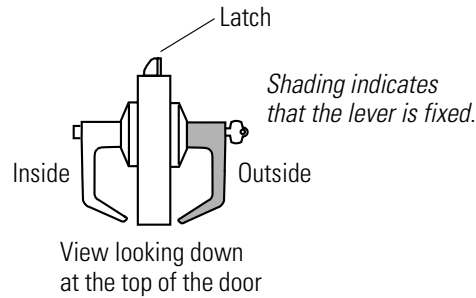
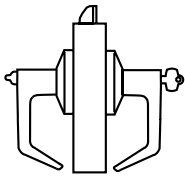

Figure 2.1 Understanding function drawings

Single-keyed functions

The following lists describe how the latchbolt, outside lever, and inside lever operate for each single-keyed 7KC function.

AB–Entrance (ANSI F109)



- Latchbolt operated by:
- inside lever
 - outside key
 - outside lever when not locked
- Outside lever locked by:
- inside button when pushed in
 - inside button when pushed in and rotated clockwise
- Outside lever unlocked by:
- inside lever when inside button pushed in but not turned
 - outside key when inside button pushed in but not turned
 - closing door when inside button pushed in but not turned
- Inside lever is always unlocked

D–Storeroom (ANSI F86)

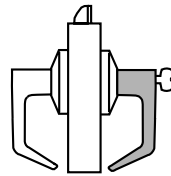

- Latchbolt operated by:
- inside lever
 - outside key
- Outside lever is always fixed
- Inside lever is always unlocked

R-Classroom (ANSI F84)

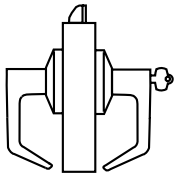

- Latchbolt operated by:
- inside lever
 - outside key
 - outside lever when not locked
- Outside lever locked by:
- outside key
- Outside lever unlocked by:
- outside key
- Inside lever is always unlocked

Non-keyed functions The following lists describe how the latchbolt, outside lever, and inside lever operate for each non-keyed 7KC function.

L-Privacy (ANSI F76)

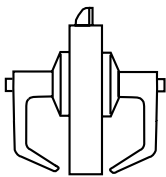

- Latchbolt operated by:
- inside lever
 - outside lever when not locked
- Outside lever locked by:
- inside button
- Outside lever unlocked by:
- inside lever
 - outside slotted button when rotated counterclockwise
 - closing door
- Inside lever is always unlocked

N-Passage (ANSI F75)

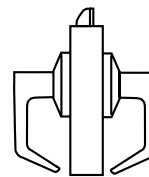

- Latchbolt operated by:
- inside lever
 - outside lever
- Outside lever is always unlocked
- Inside lever is always unlocked

Y-Exit

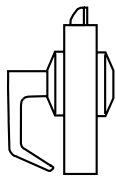

- Latchbolt operated by:
- inside lever
- Inside lever is always unlocked

1DT-Single dummy trim

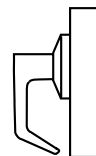

This trim assembly is a single, surface-mounted, non-rotating lever for an inactive door or a non-latching door. It can be installed on either the inside or outside of the door.

Functions by ANSI designation	ANSI no.	Function
	F75	N
	F76	L
	F84	R
	F86	D
	F109	AB

AB FUNCTION CHASSIS AND TRIM—ENTRANCE LOCK (ANSI F109)

This diagram shows the AB function lock. The chassis without trim and individual chassis parts are not available to order. See the following pages for part numbers.

- For levers, see [page 2-7](#).
- For roses, see [page 2-6](#).
- For buttons, see [page 2-6](#).

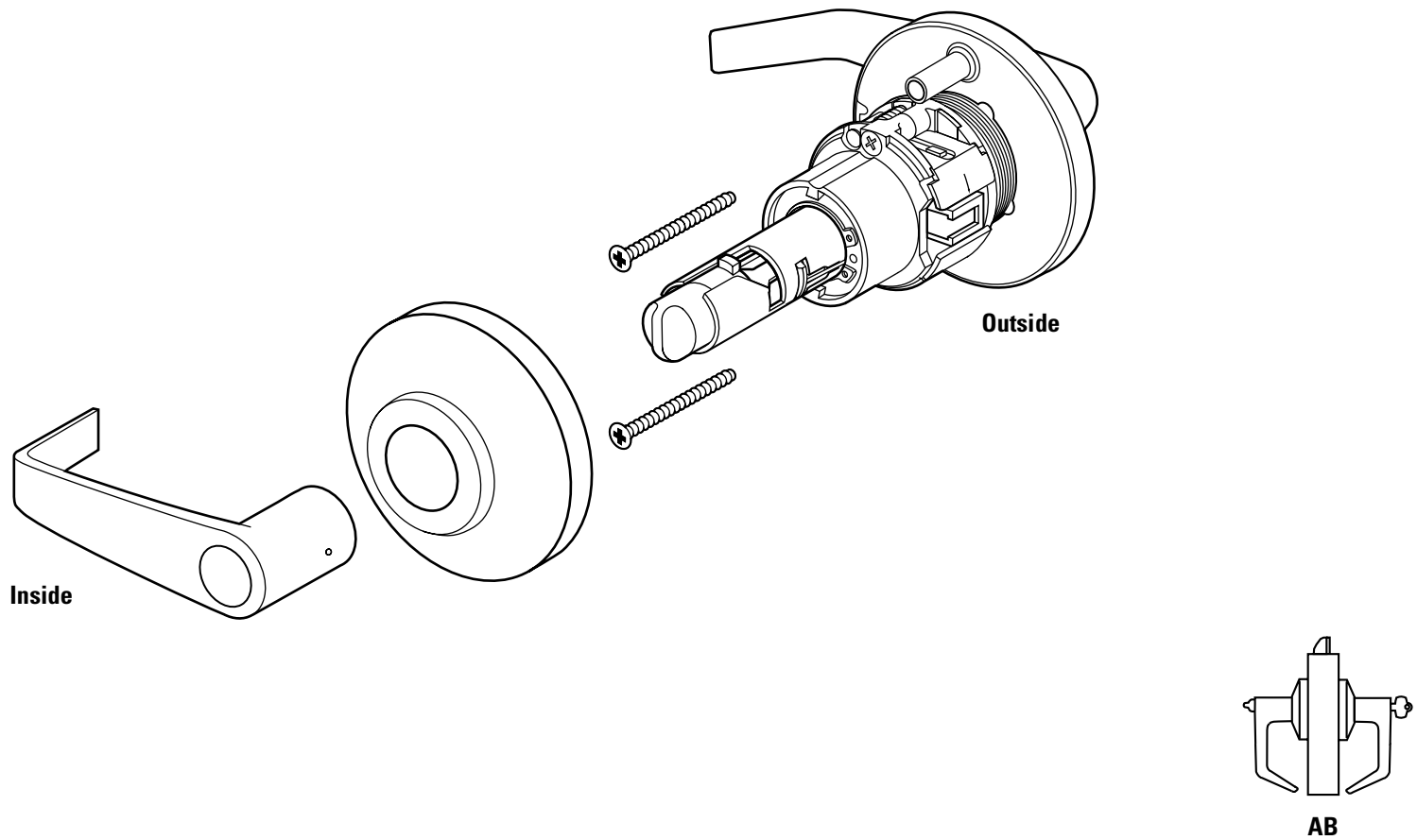

Figure 2.2 AB function exploded diagram

TRIM PARTS

The available finishes are 605, 606, 612, 613, 625, 626.

Strikes and strike boxes

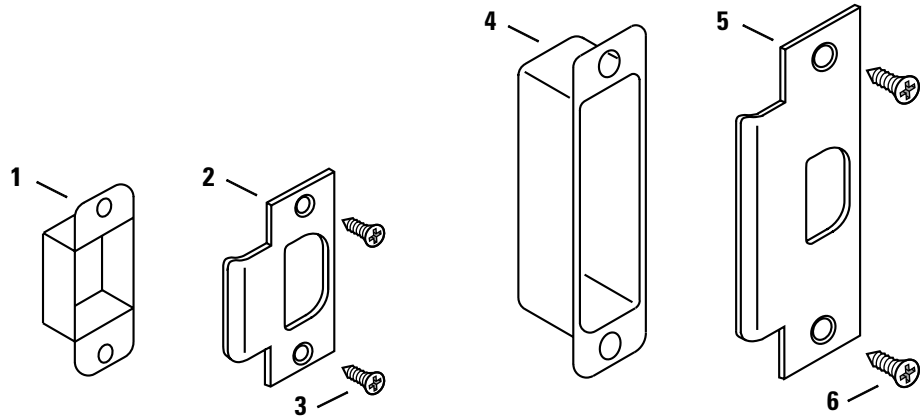

Figure 2.3 Strikes and strike boxes

Strikes and strike boxes parts list

Item	Nomenclature [†]	Part no. [†]	Qty.	Description
1	8KS1	B25640	1	Standard steel strike box
2	6KS2 [‡]	A53761	1	Standard strike
3		A25359	2	Strike screw
4	30HS4	B34380	1	ANSI plastic strike box
5	6KS3 ^{††}	A53773	1	ANSI strike
6		A18724	2	Strike screw

[†] Specify finish.

[‡] Includes one A53761 strike, two A25359 strike screws, and one B25640 strike box.

^{††} Includes one A53773 strike and two A18724 strike screws.

Roses

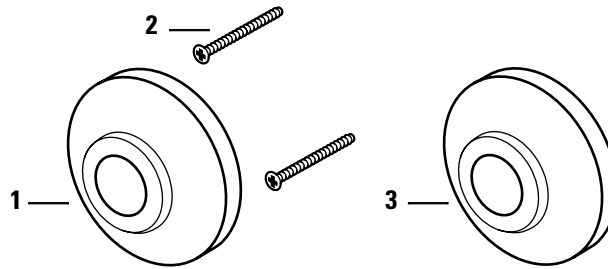

Figure 2.4 Roses

Roses parts list

Item	Part no. [†]	Qty.	Description
1	B56163	1	Inside rose
2	A55557	2	Through-bolt screw
3	B56164	1	Outside rose

[†] Specify finish.

Buttons

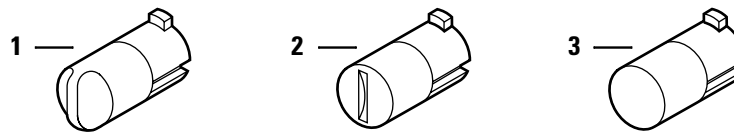

Figure 2.5 Buttons

Buttons parts list

Item	Part no. [†]	Description
1	A80050	Turn button assembly
2	A80051	Slotted button assembly
3	A80052	Push button assembly

[†] Specify finish.

**Standard levers
and throw member**

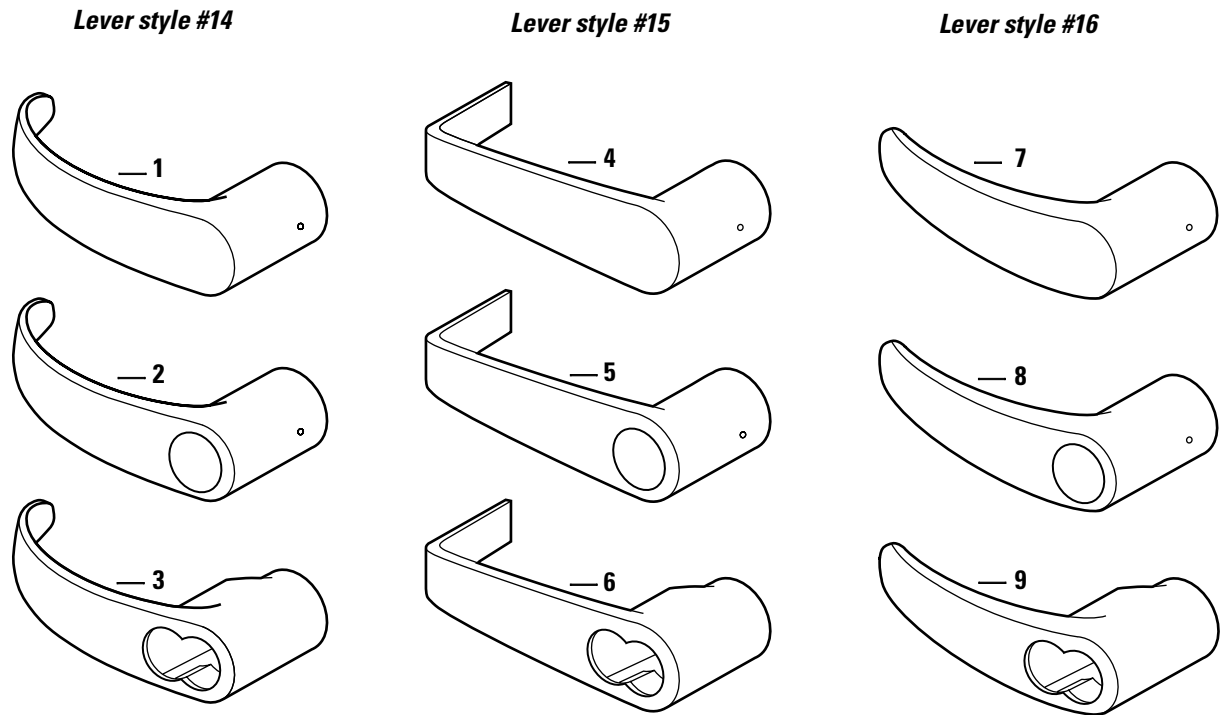

Figure 2.6 Standard levers

Standard levers parts list

Item	Style	Part no. [†]	Description
1	14	D56159	Plain lever handle
2	14	D56157	Button lever handle
3	14	D56158	Keyed lever handle
4	15	D56155	Plain lever handle
5	15	D56153	Button lever handle
6	15	D56154	Keyed lever handle
7	16	D56162	Plain lever handle
8	16	D56160	Button lever handle
9	16	D56161	Keyed lever handle

[†] Specify finish.

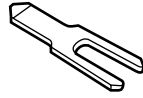

Figure 2.7 Throw member

Throw member part list

Part no.	Qty.	Description
B56165	1	7KC throw member [†]

[†] Use for 6-pin and 7-pin cores. No spacer is required.

Non-IC lever and core

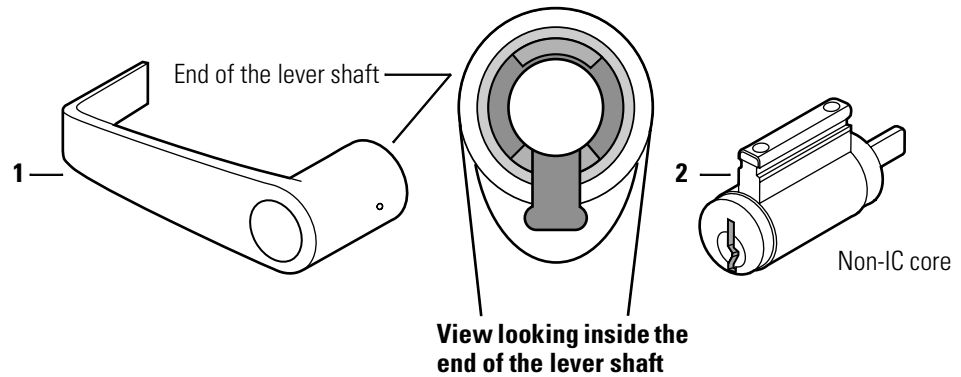

Figure 2.8 Non-IC lever and core

Non-IC lever and core parts list

Item	Style	Part no. [†]	Description
1	15	D56156	Non-IC keyed lever
2		A56188 [‡]	Non-IC core

[†] Specify finish.

[‡] Available in 606 and 626 only.

Latches

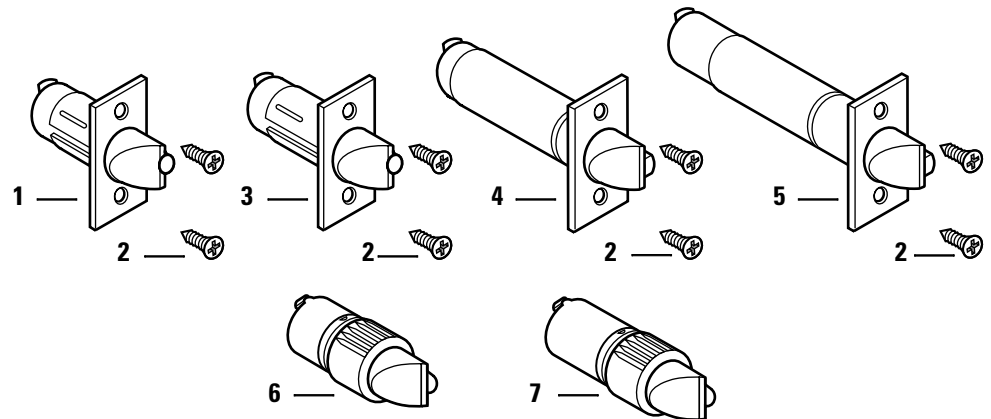

Figure 2.9 Latches

Latches parts list

Item	Part No. [†]	Nomen- clature [†]	Backset	Qty.	Description
1	A56167	7KCL2 [‡]	2 3/8"	1	Deadlocking latch
2	A25359			2	Latch screw
3	A56166	7KCL3 [‡]	2 3/4"	1	Deadlocking latch
not shown	B80189	7KCL3-NF	2 3/4"	1	Deadlocking latch with narrow face
4	B80195	6KL4-WF [‡]	3 3/4"	1	Deadlocking latch with wide face
5	B80197	6KL5-WF [‡]	5"	1	Deadlocking latch with wide face
6	A80192	6KL2-L8	2 3/8"	1	Drive-in latch
7	B80193	6KL3-L8	2 3/4"	1	Drive-in latch

[†] Specify finish.

[‡] Includes the latch and two A25359 latch screws.

Installation tools

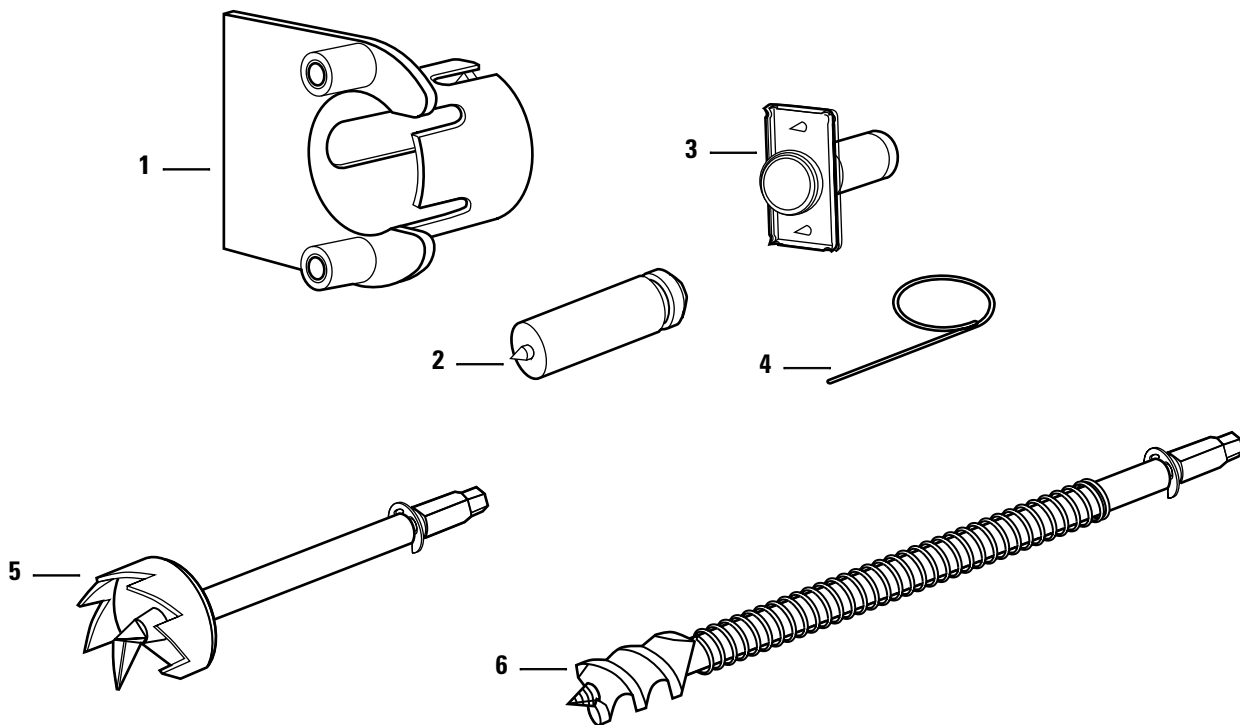

Figure 2.10 Installation tools

Installation tools parts list

Item	Nomenclature	Part no.	Description
1	KD303	C55034	Drill jig
2	KD325	A01514	Strike plate locating pin
3	KD315	1350393	Faceplate marking chisel (1 1/8" x 2 1/4")
not shown	KD312	1487975	Faceplate marking chisel (1" x 2 1/4")
4		A25341	Knob keeper tool
5	KD309	A54084	2 1/8" diameter chassis hole bit assembly [†]
6	KD318	A54085	1" diameter drill bit assembly [†]

[†] Use with the boring jig.

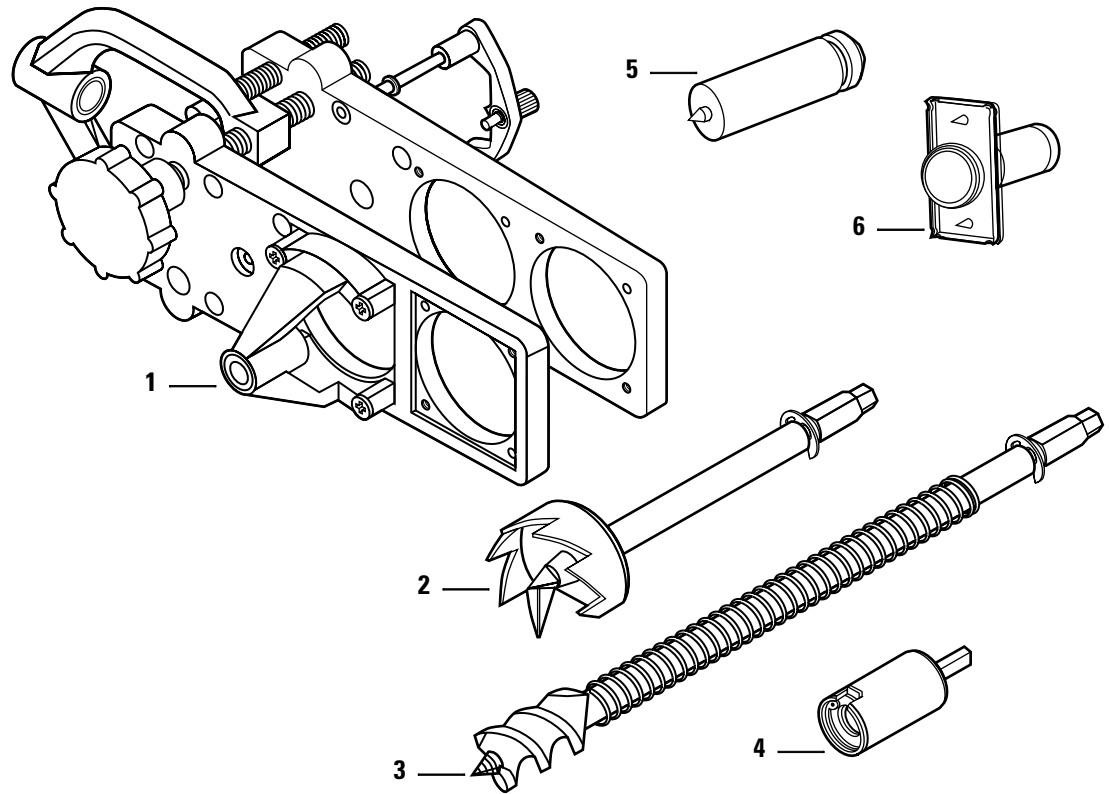

Figure 2.11 Boring jig kit

Boring jig kit parts list

Item	Nomenclature	Part no.	Description
1	N/A	N/A	Boring jig [†]
2	KD309	A54084	2 1/8" diameter chassis hole bit assembly
3	KD318	A54085	1" diameter drill bit assembly
4	N/A	N/A	Adaptor for 3/8" drill chuck [†]
5	KD325	A01514	Strike plate locating pin
6	KD315	1350393	Faceplate marking chisel (1 1/8" x 2 1/4")
not shown	KD312	1487975	Faceplate marking chisel (1" x 2 1/4")
1-6	KD304A	N/A	Boring jig kit

[†] Can only be ordered as part of the KD304A boring jig kit.

3

SERVICE AND MAINTENANCE

This chapter contains instructions for replacing components, servicing and maintaining components, and troubleshooting common problems.

To	See page
Replace levers	3-2
Replace roses	3-5
Replace button assemblies	3-8
Lubricate cores	3-10
Align chassis and trim	3-11
Troubleshoot common problems	3-12

REPLACING PARTS

Replacing the lever To remove the keyed lever:

Note: For instructions regarding non-IC levers, see *BEST Installation Instructions for 7KC Non-IC Cores and Throw Members (T80628)*.

1. Insert the control key into the core and rotate the key 15 degrees to the right.
2. Remove the core and throw member from the lever.
3. Insert a flat blade screwdriver into the figure-8 core hole and into the lever keeper.
4. Press the screwdriver blade in the direction of the arrow in [Figure 3.1](#).

Note: You will not be able to remove the lever if the screwdriver blade is inserted too far past the keeper.

5. Slide the lever off the sleeve.

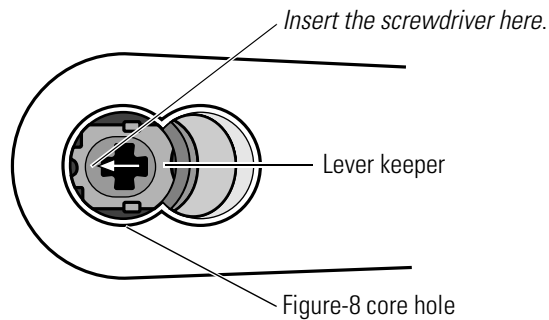

Figure 3.1 Removing the keyed lever

To remove the plain lever or button lever:

1. Insert the knob keeper tool into the hole on the shaft of the lever, as shown in [Figure 3.2](#).
2. Slide the lever off the sleeve.

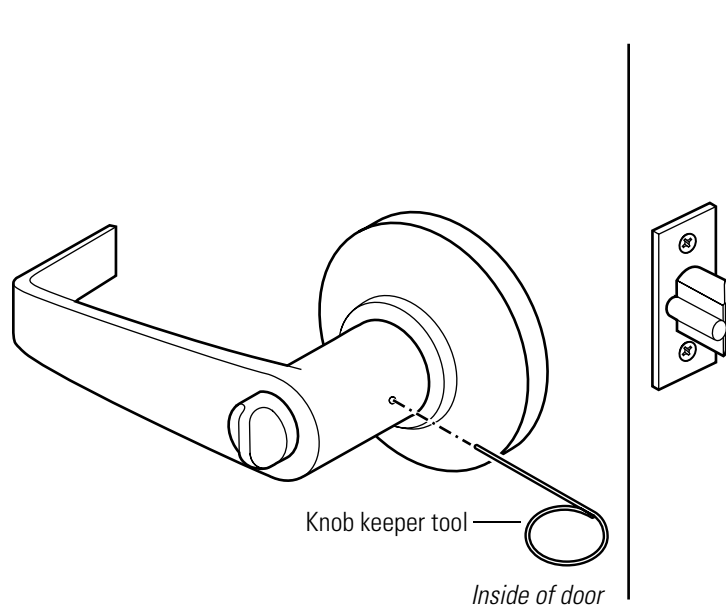

Figure 3.2 Removing the plain lever or button lever

To reinstall the lever:

Note: For instructions on reinstalling non-IC levers, see *BEST Installation Instructions for 7KC Non-IC Cores and Throw Members* (T80628).

1. Position the lever so that the handle points toward the door hinges, as shown in [Figure 3.3](#).
2. Slide the lever onto the sleeve and firmly push on the lever until it is seated.
3. Turn the levers to check that they operate smoothly.

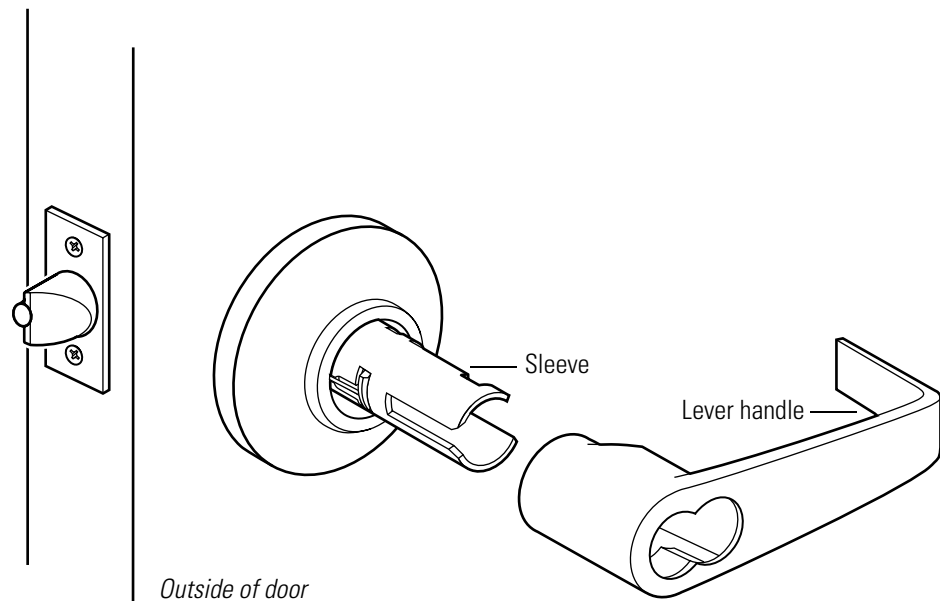

Figure 3.3 Reinstalling the lever (keyed lever shown)

4. If the lever is keyed, perform the steps below.
 - a. *For R function locks*, insert a screwdriver into the figure-8 opening and turn the locking mechanism counterclockwise as far as it will go.
For all other function locks, go to step b.
 - b. Insert the control key into the core and rotate the key 15 degrees to the right.
 - c. Using the control key, insert the core and throw member into the lever.
 - d. Rotate the control key 15 degrees to the left and remove the key.

Replacing the inside rose

To remove the inside rose:

1. Remove the inside lever ([page 3-2](#)).
2. Insert a flat blade screwdriver in the slot between the rose and liner, as shown in [Figure 3.4](#). Pry the rose until it pops off the liner.

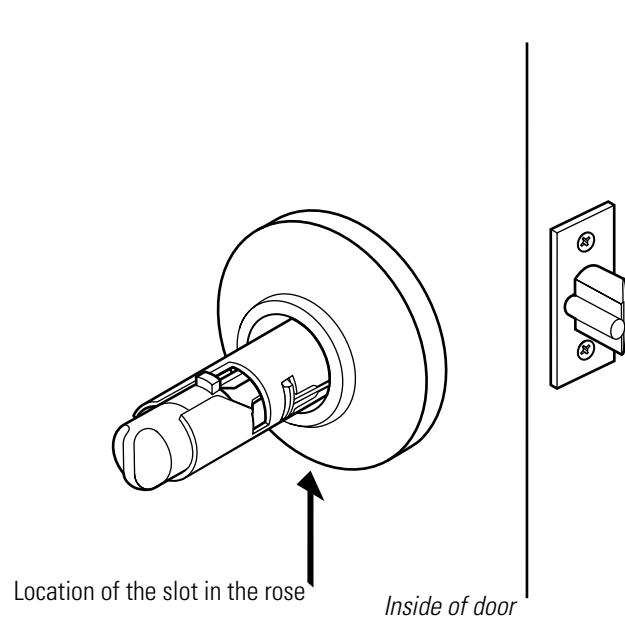

Figure 3.4 Removing the inside rose with the screwdriver

3. Unscrew the two through-bolts. Save the through-bolts.
4. Slide the liner off the sleeve. Save the liner.

To reinstall the inside rose:

1. Align the holes in the liner with the holes prepared in the door, as shown in [Figure 3.5](#).
2. Install the two through-bolts through the liner and door in the top and bottom holes.
3. Tighten the liner onto the door with the through-bolts.
4. Align the slot in the rose with the tab on the liner and firmly press until the rose is flush with the door.

5. Reinstall the inside lever ([page 3-4](#)).

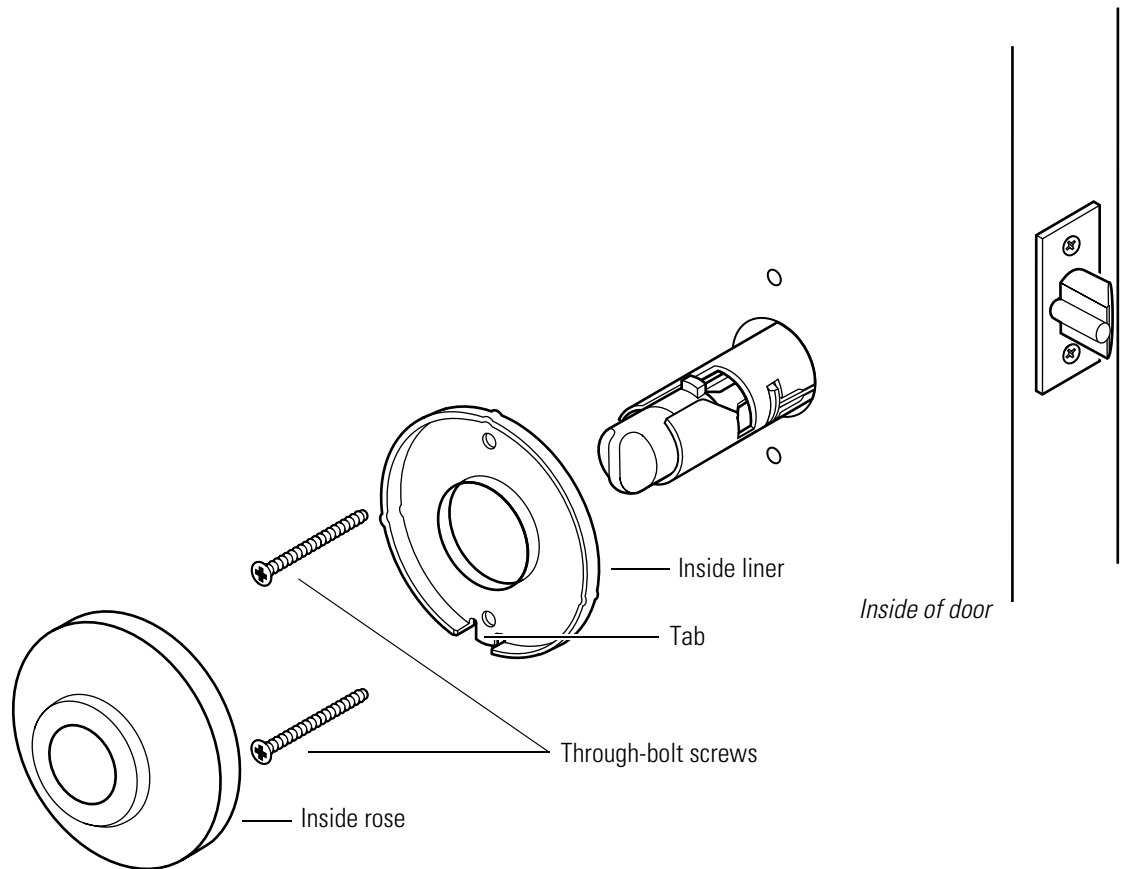

Figure 3.5 Reinstalling the inside rose and rose liner

Replacing the outside rose

To remove the outside rose:

1. Remove the following components:
 - levers ([page 3-2](#))
 - inside rose and rose liner ([page 3-5](#)).
2. Slide the chassis assembly out of the door.
3. Retract the rose locking pin, and rotate the rose and liner assembly until it is free from the hub. See [Figure 3.6](#).

- Slide the rose and liner assembly off the sleeve.

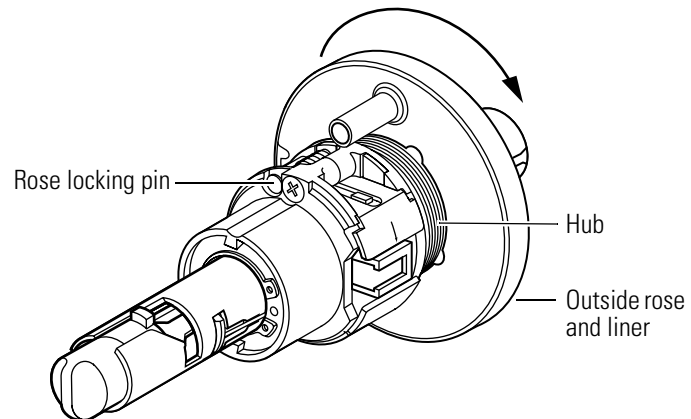

Figure 3.6 Removing the outside rose

- To separate the rose from the liner, insert a flat blade screwdriver in the slot between the rose and the liner. Pry the rose until it pops off the liner.

To reinstall the outside rose:

- Firmly press the outside rose onto the liner.
- Slide the outside rose and liner assembly onto the outside hub.
- Retract the rose locking pin, and rotate the rose and liner assembly onto the hub until the assembly reaches the bottom of the threading.
- With the rose locking pin still retracted, rotate the rose and liner assembly back off the hub. When the posts on the liner align with the chassis screws, release the rose locking pin into the indent in the liner. See [Figure 3.7](#). The pin should lock into the rose liner.

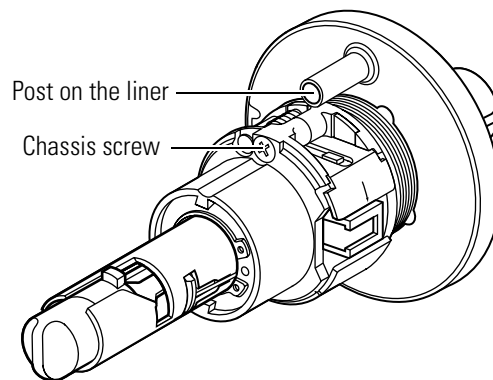

Figure 3.7 Reinstalling the outside rose

- From the outside of the door, install the chassis assembly. The outside rose and liner assembly should be flush with the door. Make sure the latch tabs engage the chassis frame and the latch tailpiece engages the retractor. See [Figure 3.8](#).

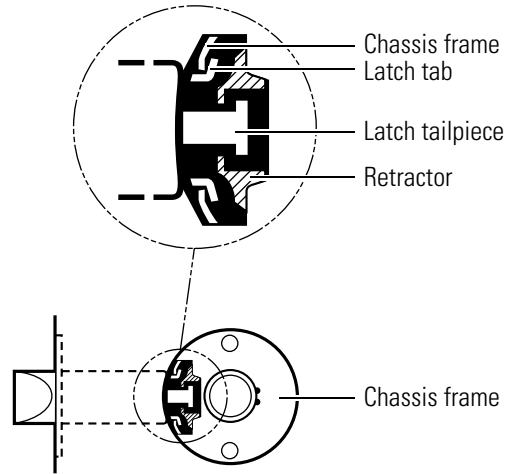

Figure 3.8 Engaging the retractor in the latch

- Reinstall the following components:
 - inside rose and rose liner ([page 3-5](#))
 - levers ([page 3-4](#)).

Replacing the button assembly

To remove the button assembly:

Note: These instructions apply for all types of button assemblies.

- Remove the lever ([page 3-2](#)).

2. Insert a flat blade screwdriver behind the plastic button retainer and pry the button assembly from the locking bar, as shown in [Figure 3.9](#).

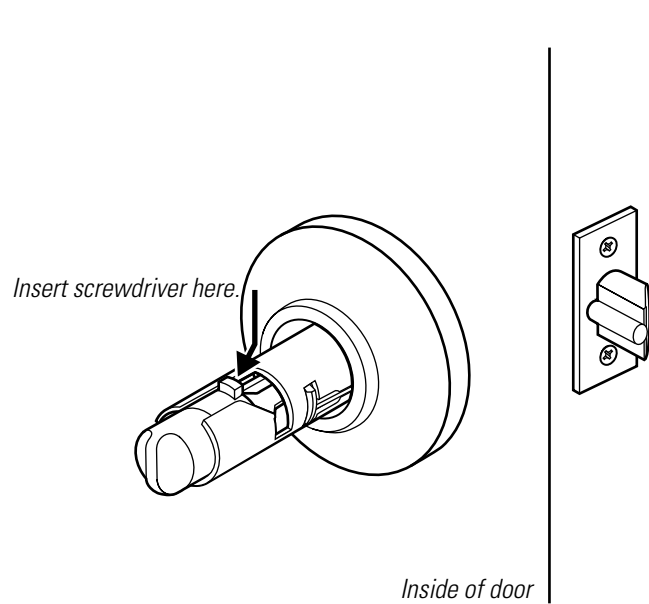

Figure 3.9 Removing the button assembly

To reinstall the button assembly:

1. Align the button tab with the top slot in the sleeve, as shown in [Figure 3.10](#).

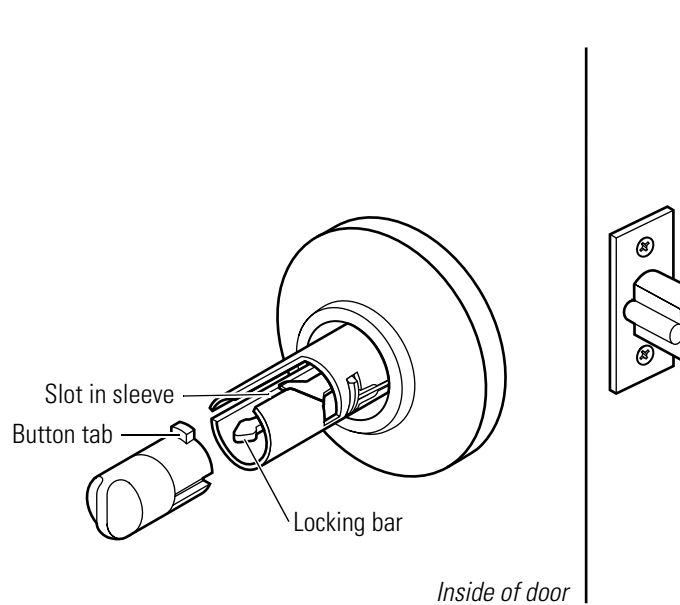

Figure 3.10 Inserting the button assembly into the sleeve

2. Firmly press the button assembly onto the locking bar until it is seated.
3. Reinstall the lever (page 3-2).

LUBRICATING THE CORES



Caution

Do not lubricate cores with oil. Doing so will only attract dirt.

For powdered graphite lubrication:

1. Dip a key in graphite. Insert the key into the keyhole and remove it; repeat several times. *OR*
Spray graphite into the keyhole. Insert the key into the keyhole and remove it; repeat several times.
2. Allow the graphite to sift into the pin segment holes.

For silicone type lubrication:

1. Clean all existing lubricant out of the core.



Caution

Do not mix graphite with a silicone-type lubricant.

2. With the core inverted, spray the lubricant into the key opening allowing the spray to penetrate the pin segment holes.

Note: When cores are installed and exposed to harsh weather conditions, silicone-type lubricants can help displace moisture as well as spread into pin segment holes and other surfaces.

ALIGNING THE CHASSIS AND TRIM

Establish a schedule to inspect locks, doors, and door hardware for proper alignment and operation. Occasionally a lock chassis and/or rose trim may become loose and require tightening.

To retighten a loose or misaligned chassis or rose trim:

1. Remove the following components:
 - levers ([page 3-2](#) or [page 3-3](#))
 - inside rose and rose liner ([page 3-5](#)).
2. Align the chassis with the latch. Make sure that the latch tabs engage the chassis frame and the latch tailpiece engages the retractor, as shown in [Figure 3.11](#). The outside rose and liner should also be flush with the door.

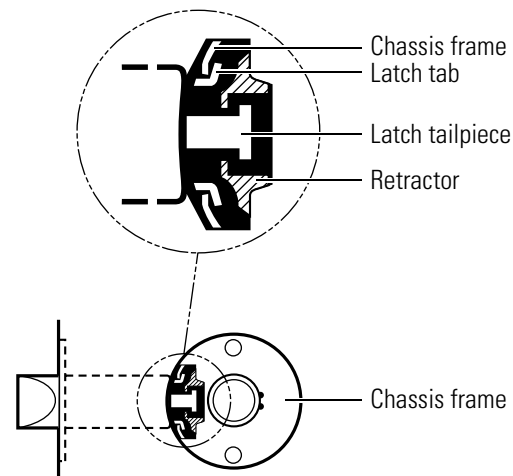

Figure 3.11 Engaging the retractor in the latch

3. If the chassis is not aligned with the latch, or the outside rose is not flush with door, perform these steps:
 - a. Slide the chassis assembly out of the door.
 - b. Retract the rose locking pin and adjust the outside rose and liner assembly as necessary, as shown in [Figure 3.12](#).
 - c. Release the rose locking pin when it is lined up with an indent in the liner and the posts on the liner match up with the chassis screws. The pin should lock into the rose liner.
 - d. From the outside of the door, install the lock chassis assembly. The outside rose and liner assembly should be flush with the

door. Make sure the latch tabs engage the chassis frame and the latch tailpiece engages the retractor.

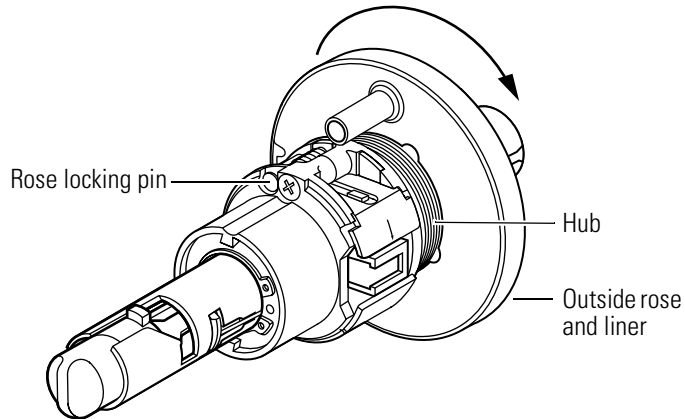

Figure 3.12 Adjusting the outside rose and liner assembly

4. Test the lever operation to make sure that the latch tailpiece does not bind with the chassis retractor.
5. Reinstall the following components:
 - inside rose and liner (page 3-5)
 - levers (page 3-4).

TROUBLESHOOTING

This table summarizes the possible causes for certain lock problems. The causes are listed in the order of likelihood. (The most likely cause is first, and so forth.)

You notice...	Possible causes include...	You should...
Lever won't return to its normal position.	There is binding between the lever and rose.	Make sure that the lock chassis is centered within the door (page 3-11).
Key spins freely, but won't retract the latch or unlock the door.	Throw member is not installed.	Install the throw member.
Core doesn't fit into the lever core hole.	Keyed lever is defective.	Replace the keyed lever (page 3-2).
Button doesn't pop out as expected.	Button retainer is damaged or bent.	Replace the button assembly (page 3-8).
Latch doesn't retract.	a. Latch tailpiece is broken. b. Latch tailpiece didn't engage the retractor correctly during installation.	a. Replace the latch assembly. b. Reinstall the lock chassis in the door (page 3-6).

A

INSTALLATION INSTRUCTIONS

The following pages contain the *Installation Instructions for 72KC-75KC Cylindrical Locks*.

For factory prepared doors only

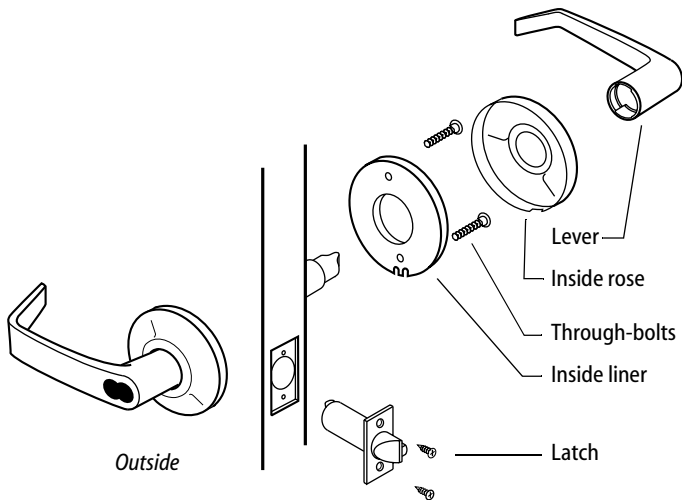

Figure 1 — Overview of installing the lock

Caution: If you use hollow metal doors, determine whether the doors are reinforced enough to support the lock. If door reinforcement is not adequate, consult the door manufacturer for information on proper reinforcement.

Simplified instructions

- 1 Install the latch so that the bevel on the latchbolt faces the strike.
- 2 Adjust the outside rose assembly so that the chassis is centered in the door. Install the chassis from the outside of the door.
- 3 Install the inside liner, through-bolts, rose, lever and strike.

For field door preparation and detailed installation instructions, see the following tasks.

1 Position template

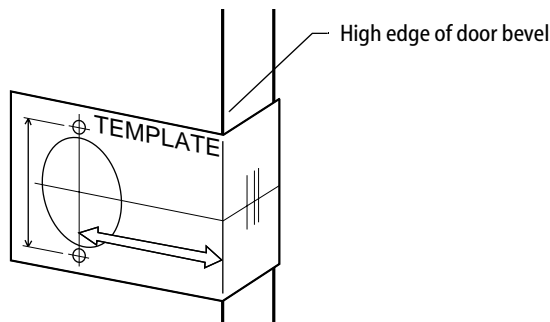

Figure 2 — Placing the template onto the door

- 1 Fold the template and place it in position on the high edge of the door bevel. See Figure 2.
- 2 Mark the drill points.

Note: The suggested height from the floor to centerline of the lock is 40 5/16". If steel frames are used, the latch centerline must be in line with the center of the strike preparation.

2 Bore two holes and install latch

- 1 Bore a 2 1/8" diameter hole from both sides of the door, to the center of the door.
- 2 Drill a 1" diameter hole from the edge of the door that intersects the 2 1/8" hole.
- 3 Mortise the door edge for the latch face.
- 4 Install the latch through the 1" diameter hole. For drive-in latches, use a rubber mallet. Latch tabs should project into the 2 1/8" diameter hole. See figure 3 in task 3.
- 5 Check the door swing.

3 Install boring jig and drill two 5/16" diameter holes

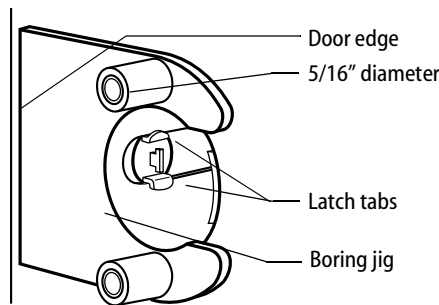

Figure 3 — Installing the boring jig onto the door

- 1 Install the boring jig onto the door and engage with the latch tabs. Make sure the front edge of the jig is parallel with the door edge. See Figure 3.
- 2 Drill two 5/16" diameter holes halfway into the door.
- 3 Turn the boring jig over and repeat steps one and two from the opposite side of the door.

Note: Replace the boring jig after ten door preparations.

4 Adjust lock to door thickness

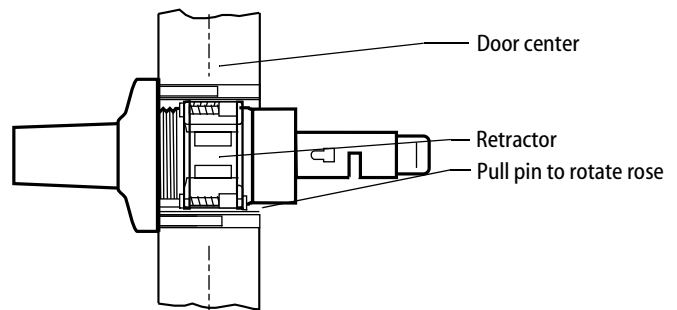

Figure 4 — Adjusting the lock to match the door thickness

- 1 Temporarily remove the latch.

- Retract the rose locking pin and rotate the outside rose liner in or out for the proper door thickness by lining up the "DOOR CENTER" mark with the center of the latch hole.
- Reinstall the latch.

Note 1: Make sure the locking pin locks into the rose liner.

Note 2: Locksets will fit 1 3/8" to 2" thick doors.

5 Engage retractor in latch

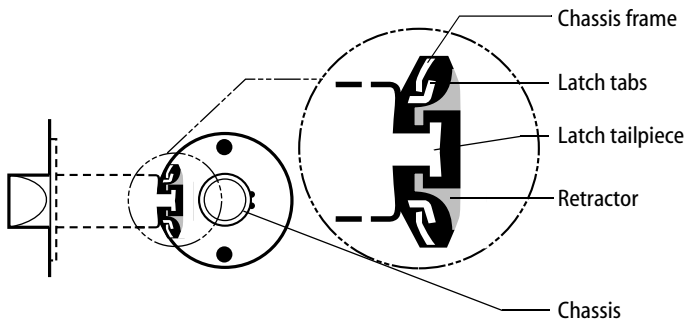

Figure 5 — Engaging the latch in the retractor

- With the latch in place, install the chassis from the outside. Make sure the latch tabs engage the chassis frame and the latch tailpiece engages the retractor. See Figure 5.

6 Install liner, rose, and lever

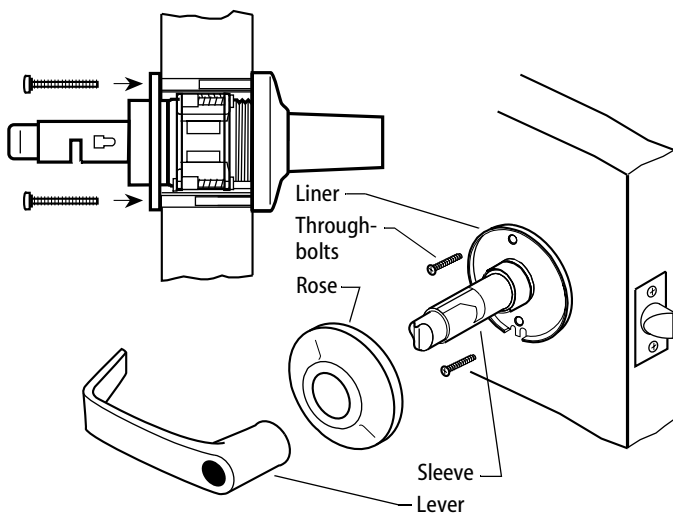

Figure 6 — Installing the inside liner, rose, and lever

- Align the holes in the liner with the holes prepared in the door.
- Install through-bolts through the liner and the door in the top and bottom holes. See Figure 6.
- Tighten the liner onto the door with the through-bolts.
- Slide the rose over the sleeve, then press the rose onto the liner. The rose should fit closely to the door surface.
- With the lever pointing toward the hinges, push the lever on firmly until seated.

7 Install strike plate

- In alignment with the center of the latchbolt, mortise the door jamb to fit the strike box and strike plate.

Caution: The deadlocking plunger of the latchbolt must not enter the strike plate opening. The plunger deadlocks the latchbolt and prevents forcing the latch when the door is closed. A gap of more than 1/8" may reduce security and/or cause improper operation of the latchbolt.

- Insert the strike box and secure the strike with the screws provided. See Figure 7.

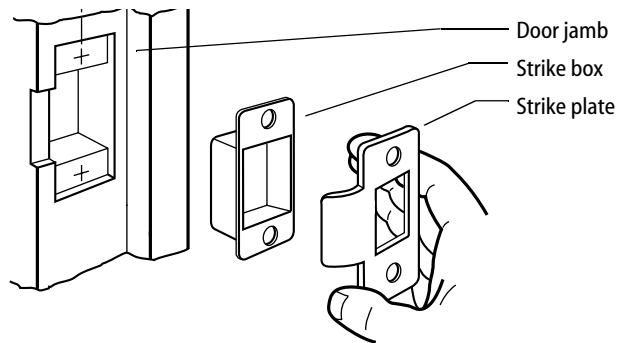

Figure 7 — Installing the strike box and strike plate

8 Install core

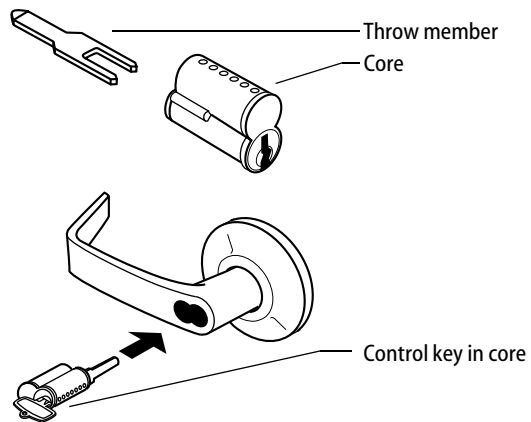

Figure 8 — Installing the core

- For R function locks**, insert a screwdriver into the figure-8 opening and turn the locking mechanism counterclockwise as far as it will go. **For all other function locks**, go to step 2.
- Insert the throw member into the core (see Figure 8 — top).
- Put the control key into the core and turn the key 15 degrees clockwise.
- Put the core and throw member into the lever with the control key (see Figure 8—bottom).
- Turn the key 15 degrees counterclockwise and remove the key.

Caution: Since the control key is a high-security key, make sure to keep it protected.

B

INDEX

A

AB function lock
 function description for 2-2
 part numbers and drawings for 2-4
aligning the chassis and trim 3-11

B

boring jig kit 2-11
buttons
 part numbers and drawings for 2-6
 reinstalling 3-9
 removing 3-8

C

certifications and standards 1-1
cores, lubricating 3-10

D

D function lock 2-2
diagrams, exploded
 see part numbers and drawings
documentation package 1-2
drawings, of parts
 see part numbers and drawings
drill jig 2-10

E

exploded diagrams
 see part numbers and drawings

F

faceplate marking chisel 2-10 to 2-11
function description
 for AB function lock 2-2
 for D function lock 2-2
 for L function lock 2-3
 for N function lock 2-3
 for R function lock 2-3
 for single dummy trim 2-3
 for Y function lock 2-3

I

installation tools 2-10

L

L function lock 2-3
latches 2-9
levers
 part numbers and drawings for 2-7
 reinstalling 3-4
 removing keyed lever 3-2
 removing plain or button lever 3-3
lock chassis
 aligning 3-11
 reinstalling in the door 3-8
 removing from the door 3-6
lubricating cores 3-10

N

N function lock 2-3
non-IC lever and core 2-8
numbers, for parts
 see part numbers and drawings

P

part numbers and drawings

for AB function lock 2-4

for buttons 2-6

for latches 2-9

for non-IC lever and core 2-8

for roses 2-6

for standard levers 2-7

for strikes and strike boxes 2-5

for throw member 2-8

R

R function lock 2-3

reinstalling

button 3-9

inside rose 3-5

lever 3-4

lock chassis in the door 3-8

outside rose 3-7

removing

button 3-8

inside rose 3-5

keyed lever 3-2

lock chassis from the door 3-6

outside rose 3-6

plain lever or button lever 3-3

roses

part numbers and drawings for
2-6

reinstalling inside rose 3-5

reinstalling outside rose 3-7

removing inside rose 3-5

removing outside rose 3-6

S

single dummy trim 2-3

strike plate locating pin 2-10 to 2-
11

strikes and strike boxes 2-5

support, technical 1-3

T

technical documentation package
1-2

technical support 1-3

throw member 2-8

troubleshooting problems 3-12

Y

Y function lock 2-3